



BESTWARE Hardware Production Co., Ltd.

Add: Block 8, No.6, Jianda Nan Road, Jiangmen, Guangdong, China

Website: www.bestware-sparkling.com

Email: business@bestware-stainless.com after-sales@bestware-stainless.com

WhatsApp: +86 18929047065 Tel: +86 750 3108801

Wechat: +86 18929047065



Website



YouTube



WhatsApp



Wechat

2025 V2.0



Commercial Water Dispenser (2 in 1) INSTRUCTION MANUAL



Applicable Models: G4DS-14, G4DS-104

ONE-STOP SOLUTION PROVIDER OF COMMERCIAL WATER DISPENSER

CATALOG

01 Instruction Manual

Dispenser Tap Operation Instructions	01
Setting Dispensing Time on Tap	02
Chilling Unit Operation Instructions	03
Usage Precautions	04
Error Codes and Troubleshooting	06

07 Installation Manual

Equipment Assembly Components Overview	07
Required Space and Placement Requirements	09
Water and Electrical Positioning Requirements	10
Ventilation Grid Installation	11
Countertop Cut-out Size	12
Dispenser Tap Installation Steps	12
Tubing Connection Precautions	14
Communication Cable Connection Precautions	15
Power-on Precautions	16
UV Sterilization Module Precautions	17
RO Filtration Unit Wastewater Drain Tube Precautions	18
Safety Valve Drain Hose Precautions	18
Connection Diagram	20
Post-installation Precautions	21
Pre-startup Precautions	21

22 Warranty & Disclaimer

Dispenser Tap Operation Instructions

1. Dispensing Chilled Water:

- 1 Rotate knob to chilled water mode.
- 2 Press center of the knob to start dispensing.
- 3 Display dispensing countdown.



2. Dispensing Ambient Water:

- 1 Rotate knob to ambient water mode.
- 2 Press center of the knob to start dispensing.
- 3 Display dispensing countdown.



Setting Dispensing Time on the Dispenser Tap

1. On the selected mode, press and hold the center of the screen for 5 seconds to enter the time setting. (Each mode has its own independent time setting with power-off memory. The following example uses chilled water mode.)

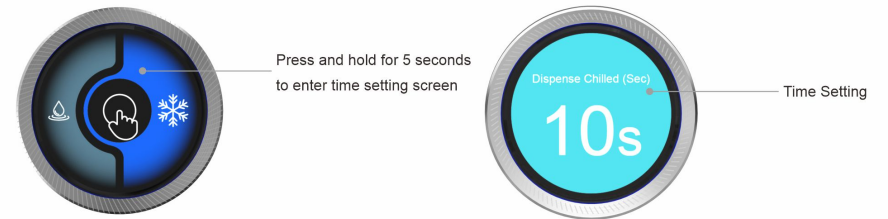

2. Rotate knob to set desired time (1-60 seconds).

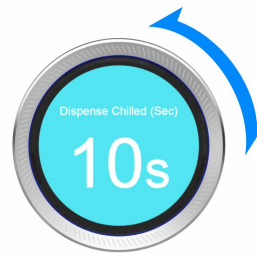

3. Press the screen again to confirm.



Chilling Unit Operation Instructions



1. Press "+" or "-" on the control panel to set the desired temperature (0°C-8°C).

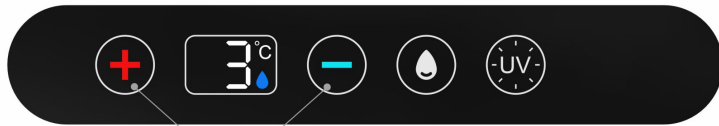

Press to set temperature

2. Indicator Status:

Solid blue drop: Cooling complete

Flashing blue drop: Cooling in progress

Solid white drop and UV lights: Normal operation

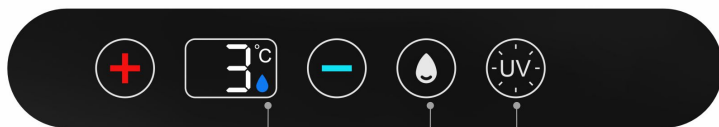

Blue drop solid indicates cooling complete

Blue drop flashing indicates cooling in progress

Flashes when refilling water

Flashes when dispensing chilled or ambient water

Usage Precautions

1. Chilling Unit Precautions:

❶ When moving the unit, keep it upright (do not tilt more than 45°) to prevent damage to the refrigeration system and ensure proper operation.

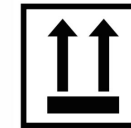

❷ After relocation, let the unit stand for at least 2 hours before powering on.



❸ Keep the power plug dry when connecting to power. Never plug or unplug with wet hands.



4 After installation, verify that all wiring and tubing connections are correct before powering on.



5 During power outages or cleaning, unplug the unit and wait at least 5 minutes before restarting to prevent compressor damage from rapid cycling.

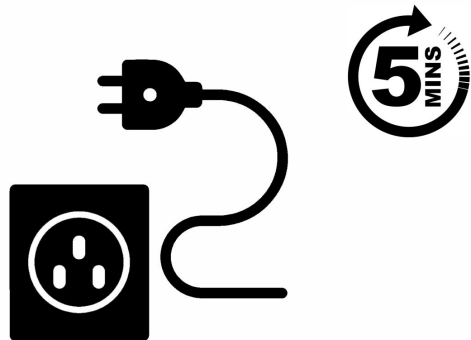

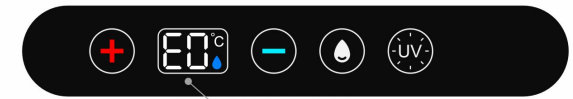

Chilling Unit Error Codes and Troubleshooting

1. Chilling Unit



Error Code Display

Error Code	Error Name	Symptoms	Possible Causes	Solution	Image
E0	Water Leakage Protection	All loads shut down, water dispensing disabled (E0 has the highest priority)	Loose internal piping in chilling unit causing leakage	Remove side panel to check and re-secure any loose pipes	/
			Water accumulation in leakage protector	Remove left side panel to clean accumulated water in leakage protector	
			Water tank leakage	Contact after-sales service	/
E1	Temperature Sensor Fault	Chilling disabled; dispensing and other functions normal	Damaged or faulty temperature sensor	Contact after-sales service	/
E3	Cooling Fault	Water temperature unchanged after 20 minutes or large deviation from set temperature	Foreign object blocking both air inlets of the unit	Remove any foreign objects blocking both air inlets	
			Cooling fan failure or abnormal (stopping after cooling is normal)	Contact after-sales service	
/	No Error Code, Cooling Fault	Water temperature unchanged after 20 minutes or large deviation from set temperature	Not enough space for hot air to escape	Place the unit in a well-ventilated area with good airflow	
E7	Chilling Tank Refill Error	Chilling tank not refilled within 20 minutes	No water supply to chilling tank	Check if water supply is normal	/

Note: Contact after-sales service if above solutions don't resolve the issue

Equipment Assembly Components Overview

1. Dispenser Tap Assembly Components

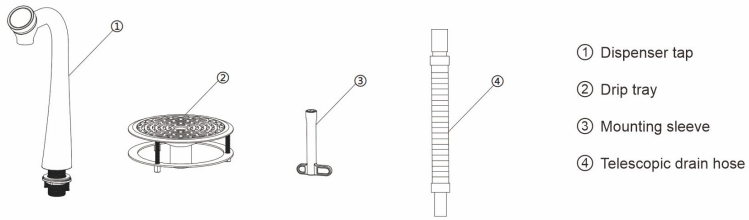

2. Chilling Unit Assembly Components

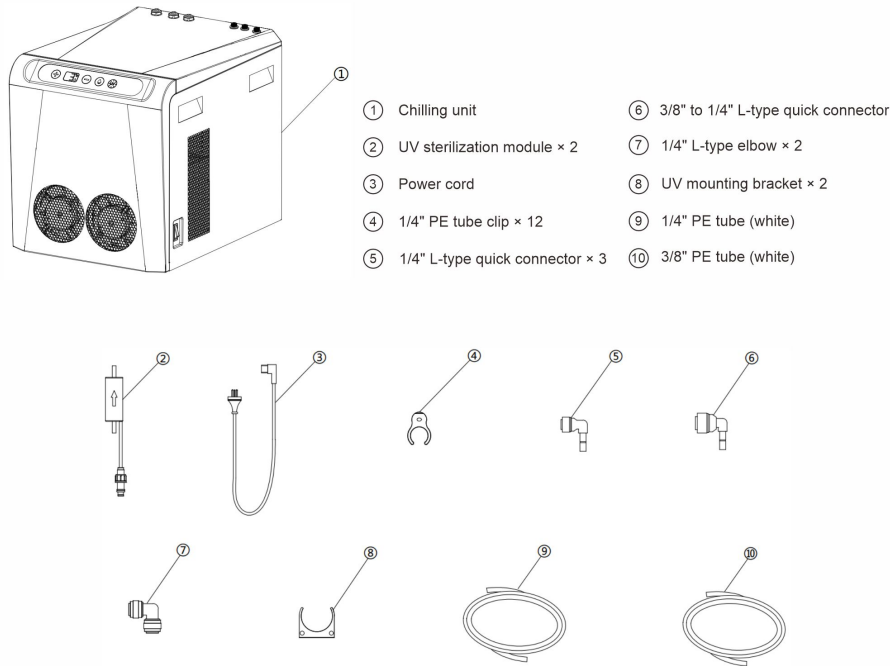

4. RO Filtration Unit Assembly Components

RO filtration unit (optional)

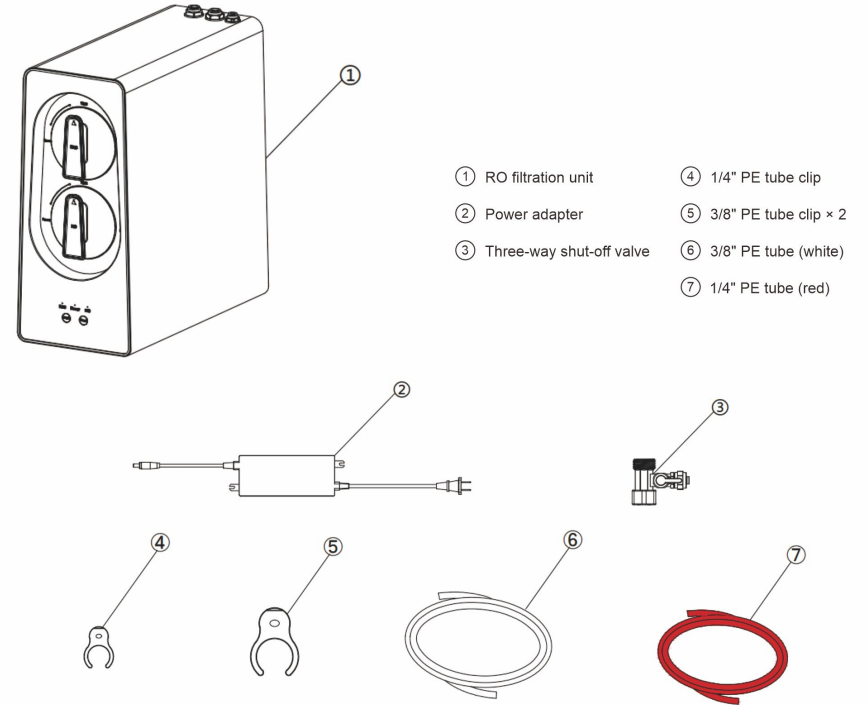

Required Space and Placement Requirements

1. Minimum Clearance for Chilling Unit

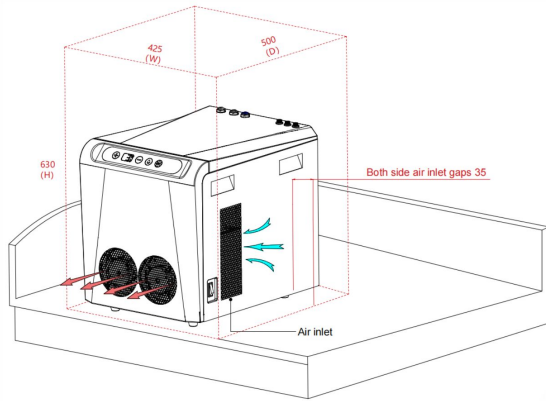

Unit (mm)

Chilling Unit Size
355 x 464 x 438 (W x D x H)

2. Minimum Clearance for RO Filtration Unit (Applicable only to Bestware Unit)

RO filtration unit (optional)

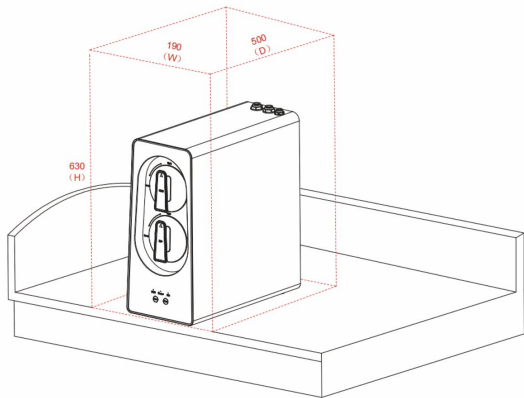

Unit (mm)

RO Filtration Unit Size
180 x 386 x 408 (W x D x H)

Water and Electrical Positioning Requirements

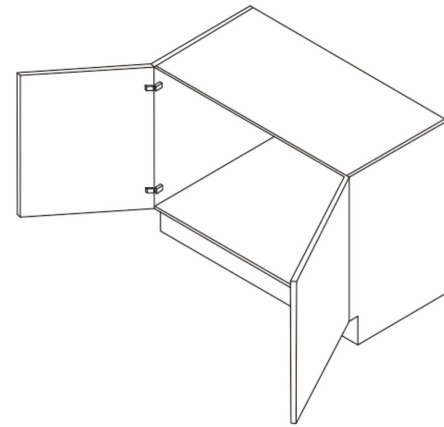

Unit (mm)

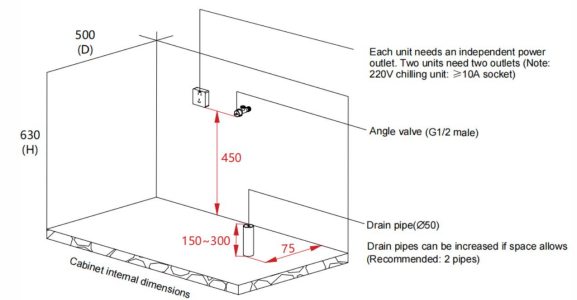

Ventilation Grid Installation

The ventilation grid must be installed to ensure proper ventilation of the unit.

1. Identify the air outlet location of the chilling unit.

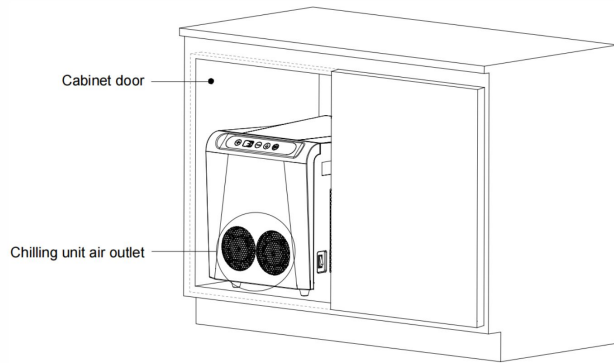

2. Cut an opening on the cabinet door aligned with the air outlet and install the ventilation grid.

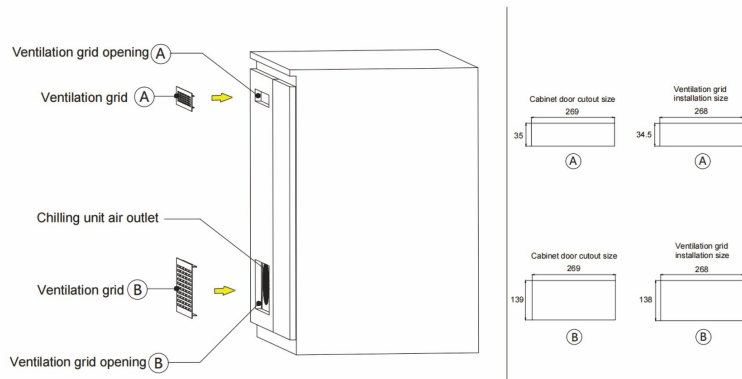

Countertop Cut-out Size

Before installing the dispenser tap, the countertop must be prepared with the required cut-out according to specifications.

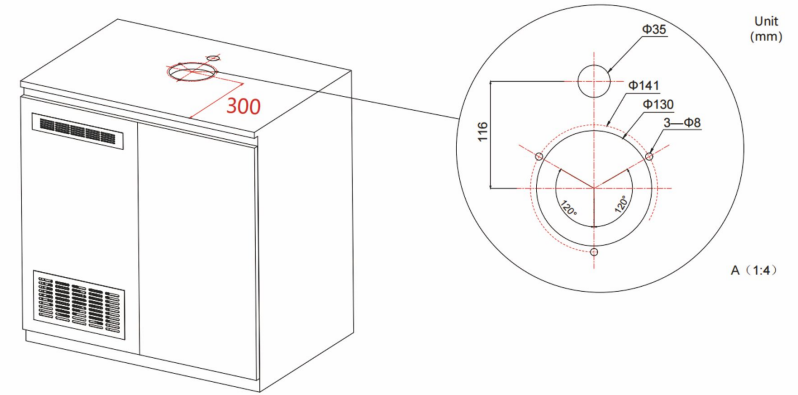

Dispenser Tap Installation Steps

1. Secure Drip Tray: Install the drip tray on the countertop. Secure the nut underneath the countertop first, then tighten it further using the mounting sleeve. (Maximum countertop thickness for drip tray installation: 36mm)

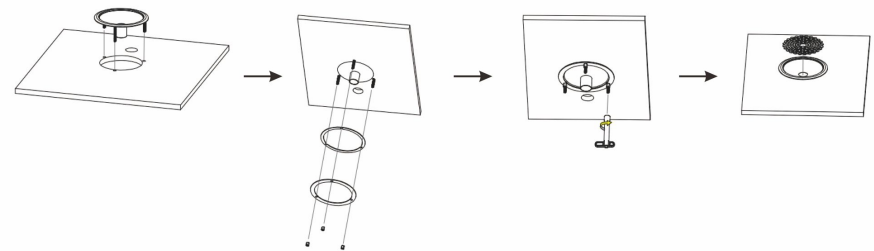

2. Secure Dispenser Tap: Install dispenser tap on countertop. First, fasten mounting nut underneath countertop, then tighten using Phillips screwdriver. (Maximum countertop thickness for dispenser tap installation: 40mm)

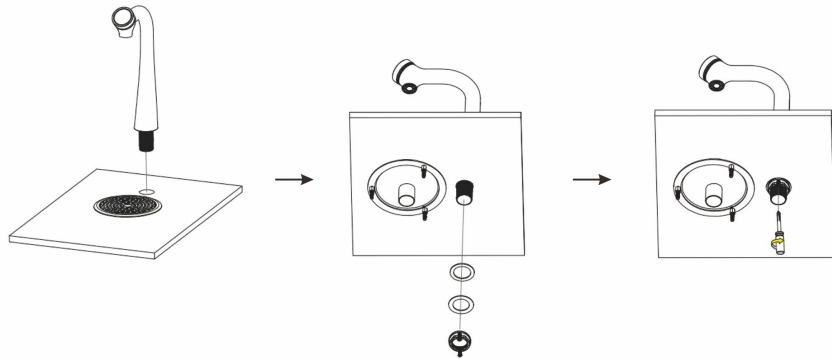

3. Install Telescopic Drain Hose: Connect the drip tray and the drain pipe using the telescopic drain hose.

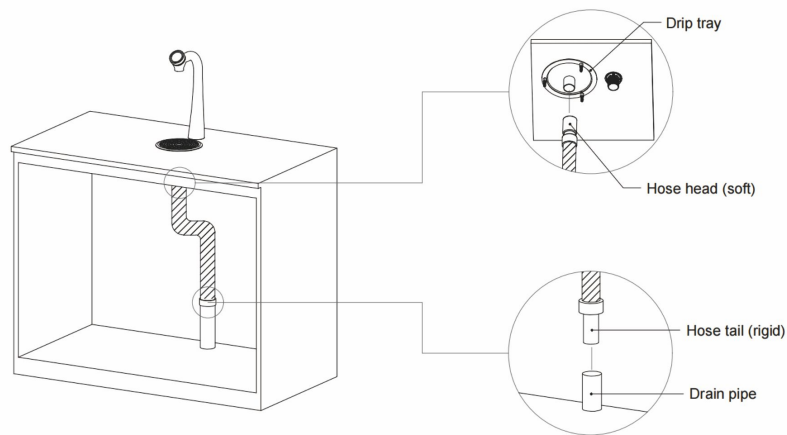

Tubing Connection Precautions

1. Take care to install correctly. No kinks, sags, pinches or loops.
2. The tubes and pipes must not be under tension when installed.
3. PE tubes must be trimmed to avoid loops and kinks. Take care when positioning before cutting and make a clean cut straight across the hose, using a sharp blade.

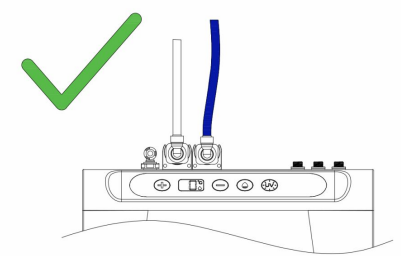
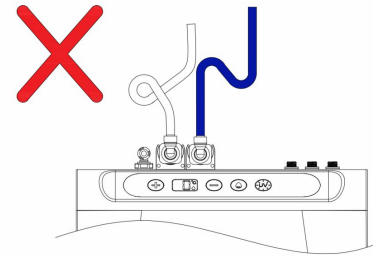

4. Follow the diagram and steps for proper PE tube handling.

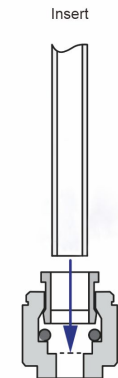

1. Cut tube clean and square.
2. Push tube firmly to end stop.

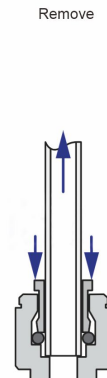

1. Press collet down.
2. Pull tube out.

Communication Cable Connection Precautions

1. When connecting the communication cable, make sure the connectors are properly aligned.

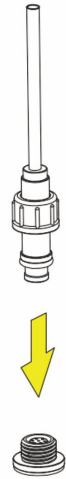

Align connectors

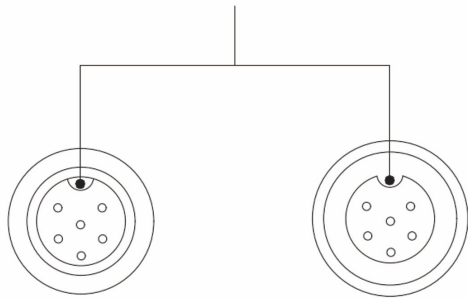

Power-on Precautions

1. Do not connect the power supply before installation is complete to prevent unit malfunction.

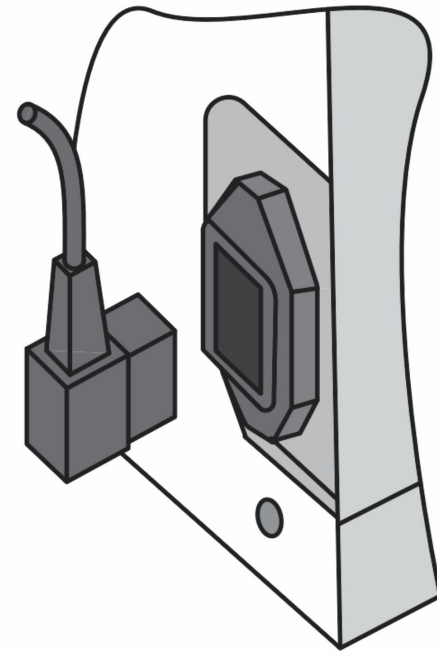

UV Sterilization Module

1. Pay attention to the arrow direction on the UV sterilization module during assembly.

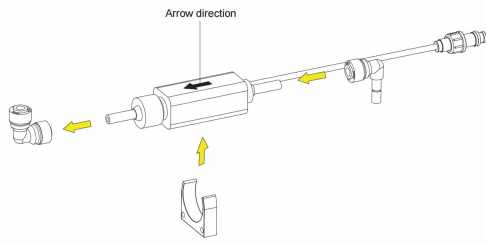

2. After assembling the UV sterilization module, secure it with the tube clip.

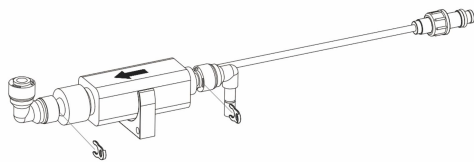

RO Filtration Unit Wastewater Drain Tube Precautions

1. The wastewater drain tube must be securely fixed to the drain pipe to prevent it from popping out due to internal pressure.

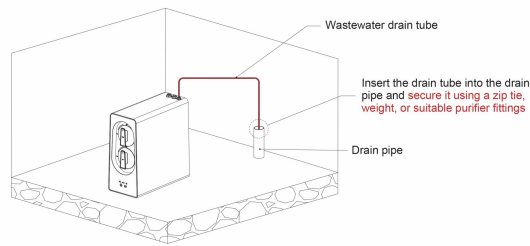

Safety Valve Drain Hose Precautions

1. The safety valve drain hose must be secured to the drain pipe.

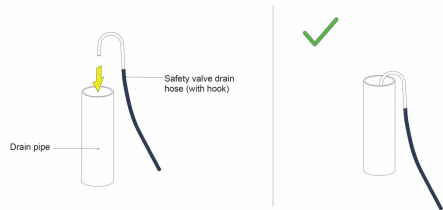

Connection Diagram



Open to left

Connection Diagram

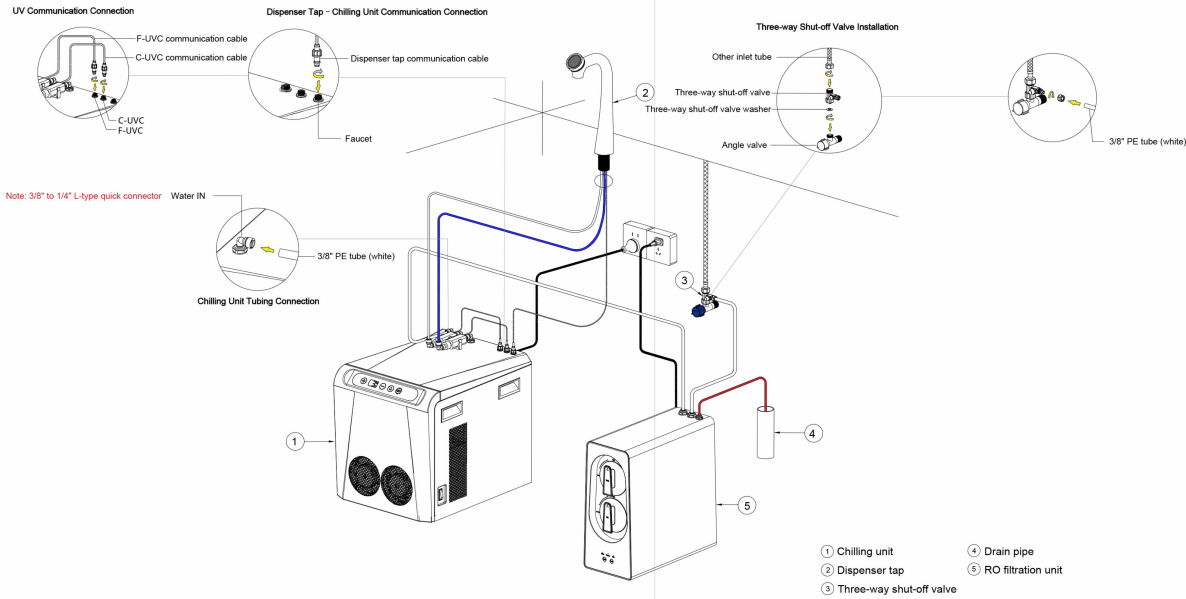

Post-installation Precautions

1. Check that all communication cables, water lines, and PE tubes are correctly connected. After confirming everything is secure, make sure all tube-to-fitting connections are locked in place with tube clips.

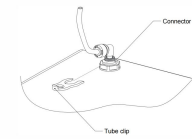

Pre-startup Precautions

1. Water Supply: Open the angle valve first, then open the three-way shut-off valve to supply water.

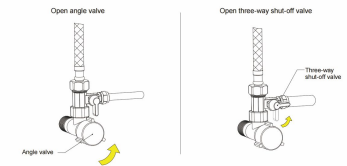

2. Power On Units: After confirming there are no leaks in the piping, turn on the power switches of the chilling unit.

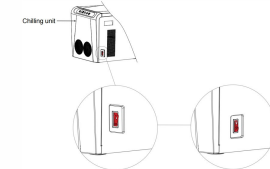

Warranty & Disclaimer

● Warranty

Coverage: Full Unit Warranty (applicable only to the original purchaser — B2B customers only; non-transferable)

Scope: Dispenser Tap, Chilling Unit

Period: 18 months from the date of purchase

● Important Notice: This product must be connected to filtered water only (recommended TDS value below 50)

The following conditions are not covered under warranty:

- ① Yellowish water caused by sediment, sand, or impurities in the water source
- ② Malfunctions or irregularities caused by clogged impurities in the water source
- ③ No water output due to limescale buildup
- ④ Reduced cooling performance due to limescale
- ⑤ Malfunctions or irregularities in the chilling unit caused by limescale
- ⑥ Any other operational issues or malfunctions resulting from limescale buildup

● Disclaimer

1. Damage caused by human error or misuse:

- ① Physical damage from collisions, drops, or crushing during transportation or installation
- ② Malfunctions due to unauthorized modifications or the use of non-original parts
- ③ Improper installation or use not in accordance with the instruction manual
- ④ Damage caused by abnormal voltage (e.g., voltage instability) or improper power supply (e.g., no grounding)
- ⑤ Malfunctions due to unsuitable environmental conditions (e.g., excessively high/low temperatures, high humidity, direct sunlight exposure, poor ventilation)
- ⑥ Clogging or damage caused by poor water quality
- ⑦ Malfunctions caused by liquid or foreign objects entering non-designated internal areas of the product
- ⑧ Damage caused by insects, rodents, or pets
- ⑨ Corrosion, discoloration, or deformation caused by improper cleaning (e.g., using strong acids or alkalis)

2. Force Majeure Events:

- ① Natural disasters such as fire, flooding (including water damage from burst pipes), earthquakes, lightning strikes, typhoons, etc.
- ② Accidental events such as damage caused by transportation, war, riots, theft, or government actions
- ③ Interruptions or abnormalities in public utilities, including power, water, and gas supply, resulting in indirect loss or equipment malfunction

3. Damage to Appearance Components or Normal Wear and Tear:

- ① Natural aging of plastic parts or worn labels that do not affect the product's functionality are generally not covered under warranty
- ② Minor scratches, dents, or discoloration occurring during transportation or use that do not affect functionality are typically not covered
- ③ Reasonable performance changes over time—such as slight decreases in cooling efficiency or slight increases in operating noise—are considered normal wear and are not covered by the warranty as long as they remain within acceptable limits

4. Expired Warranty Period:

Warranty services are only provided within the specified valid period

5. Failure to Provide Valid Proof of Purchase:

- ① Inability to present a valid purchase invoice, receipt, or record to confirm the date of purchase
- ② The product serial number label is torn, altered, or illegible (this is generally considered grounds for disqualification from warranty coverage)

6. Unauthorized Repairs:

During the warranty period, any repair conducted by an unauthorized party or performed without official approval from the brand may void the warranty

● Warranty Service Procedure

1. How to Request Service:

- ① Customer Service Hotline: +86 750 3108801 (Weekdays, 8:30-17:30)
- ② after-sales@bestware-stainless.com
- ③ Contact your sales representative

2. Required Documentation:

Please provide a valid original purchase invoice, electronic order, purchase record, or purchase contract

● Special Notes

- ① Out-of-Warranty Repairs: A fee will be charged, including the cost of parts and a service fee (Standard rate: ____ CNY/visit)
- ② Extended Warranty: Additional warranty coverage of ____ years is available for purchase (please consult your sales representative for details)
- ③ Policy Updates: Brand policies are subject to change. Please refer to the latest official announcements on our website

⚠ Important Recommendations:

- ① Please review the warranty disclaimers carefully before purchase, and read the user manual thoroughly to ensure proper product usage
- ② Keep your proof of purchase safely during the warranty period

● Right of Interpretation:

The company reserves the final right of interpretation for the warranty terms and disclaimer scope

Version	Change Description
2025 V1.0	Initial release
2025 V2.0	1. Upgraded to independent tube design, with a dedicated tube for each water type
	2. Line diagrams optimized
	3. Tap display interface optimized
	4. Main unit appearance optimized with recessed handholds added