



BESTWARE Hardware Production Co., Ltd.

Add: Block 8, No.6, Jianda Nan Road, Jiangmen, Guangdong, China

Website: www.bestware-sparkling.com

Email: business@bestware-stainless.com after-sales@bestware-stainless.com

WhatsApp: +86 18929047065 Tel: +86 750 3108801

Wechat: +86 18929047065



Website



YouTube



WhatsApp



Wechat

2026 V1.0



Commercial Sparkling Water Dispenser (3 in 1) INSTRUCTION MANUAL



Applicable Models: G2DS-13, G2DS-103

ONE-STOP SOLUTION PROVIDER OF COMMERCIAL SPARKLING WATER DISPENSER

CATALOG

01 Instruction Manual

| | |
|--------------------------------------|----|
| Dispenser Tap Operation Instructions | 01 |
| Setting Dispensing Time on Tap | 02 |
| Chilling Unit Operation Instructions | 03 |
| Usage Precautions | 06 |
| Error Codes and Troubleshooting | 09 |

07 Installation Manual

| | |
|--|----|
| Equipment Assembly Components Overview | 07 |
| Required Space and Placement Requirements | 09 |
| Water and Electrical Positioning Requirements | 10 |
| Ventilation Grid Installation | 11 |
| Countertop Cut-out Size | 12 |
| Dispenser Tap Installation Steps | 12 |
| CO ₂ Cylinder Precautions | 14 |
| Tubing Connection Precautions | 15 |
| Communication Cable Connection Precautions | 16 |
| Power-on Precautions | 16 |
| UV Sterilization Module Precautions | 17 |
| RO Filtration Unit Wastewater Drain Tube Precautions | 18 |
| Safety Valve Drain Hose Precautions | 18 |
| Connection Diagram | 19 |
| Post-installation Precautions | 21 |
| Pre-startup Precautions | 21 |
| Initial Sparkling Water Commissioning | 22 |

24 Warranty & Disclaimer

Dispenser Tap Operation Instructions

1. Dispensing Chilled Water:

- 1 Rotate knob to chilled water mode.
- 2 Press center of the knob to start dispensing.
- 3 Display dispensing countdown.



2. Dispensing Sparkling Water:

- 1 Rotate knob to sparkling water mode.
- 2 Press center of the knob to start dispensing.
- 3 Display dispensing countdown.



3. Dispensing Ambient Water:

- 1 Rotate knob to ambient water mode.
- 2 Press center of the knob to start dispensing.
- 3 Display dispensing countdown.



Setting Dispensing Time on the Dispenser Tap

1. On the selected mode, press and hold the center of the screen for 5 seconds to enter the time setting.
- (Each mode has its own independent time setting with power-off memory. The following example uses chilled water mode.)

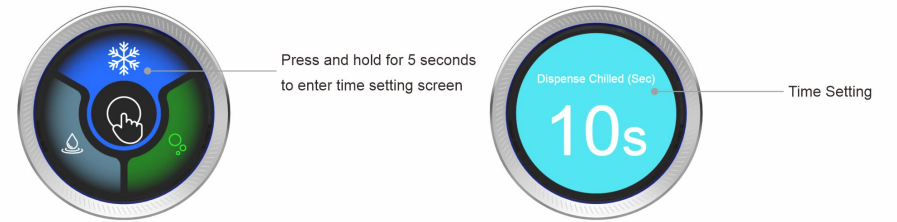

2. Rotate knob to set desired time (1-60 seconds).

3. Press the screen again to confirm.

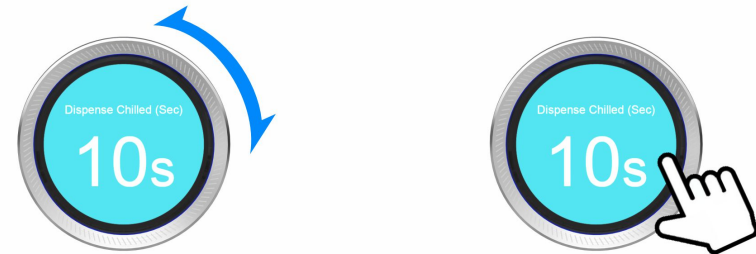

Chilling Unit Operation Instructions



1. Press "+" or "-" on the control panel to set the desired temperature (0°C-8°C).

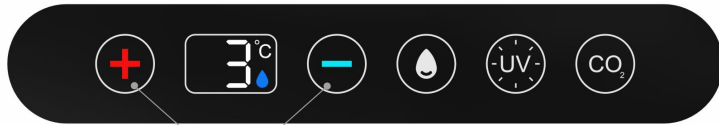

Press to set temperature

2. Indicator Status:

Solid blue drop: Cooling complete

Flashing blue drop: Cooling in progress

Solid white drop, UV, and CO₂ lights: Normal operation

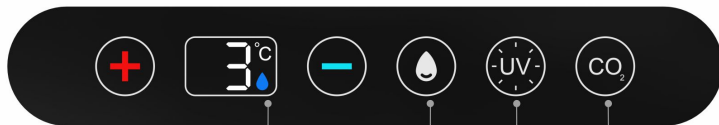

Blue drop solid indicates cooling complete

Blue drop flashing indicates cooling in progress

Flashes when refilling water

Flashes when dispensing chilled, sparkling, or ambient water

Flashes when CO₂ is depleted

Usage Precautions

1. Chilling Unit Precautions:

❶ When moving the unit, keep it upright (do not tilt more than 45°) to prevent damage to the refrigeration system and ensure proper operation.

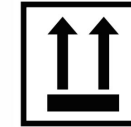

❷ After relocation, let the unit stand for at least 2 hours before powering on.



❸ Keep the power plug dry when connecting to power. Never plug or unplug with wet hands.



4 After installation, verify that all wiring and tubing connections are correct before powering on.



5 During power outages or cleaning, unplug the unit and wait at least 5 minutes before restarting to prevent compressor damage from rapid cycling.



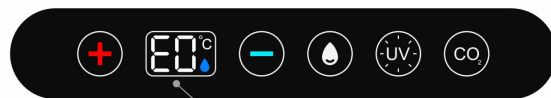

Chilling Unit Error Codes and Troubleshooting

1. Chilling Unit



Error Code Display

| Error Code | Error Name | Symptoms | Possible Causes | Solution | Image |
|------------|----------------------------------|--|--|--|---|
| E0 | Water Leakage Protection | All loads shut down, water dispensing disabled (E0 has the highest priority) | Loose internal piping in chilling unit causing leakage | Remove side panel to check and re-secure any loose pipes | / |
| | | | Water accumulation in leakage protector | Remove left side panel to clean accumulated water in leakage protector |  |
| | | | Water tank leakage | Contact after-sales service | / |
| E1 | Temperature Sensor Fault | Chilling disabled; dispensing and other functions normal | Damaged or faulty temperature sensor | Contact after-sales service | / |
| E3 | Cooling Fault | Water temperature unchanged after 20 minutes or large deviation from set temperature | Foreign object blocking both air inlets of the unit | Remove any foreign objects blocking both air inlets |  |
| | | | Cooling fan failure or abnormal (stopping after cooling is normal) | Contact after-sales service | |
| | | | Not enough space for hot air to escape | Place the unit in a well-ventilated area with good airflow | |
| / | No Error Code, Cooling Fault | Water temperature unchanged after 20 minutes or large deviation from set temperature | Not enough space for hot air to escape | Place the unit in a well-ventilated area with good airflow | / |
| E4 | Bubble Tank Refill Error | Bubble tank not refilled within 15 minutes | No water supply to bubble tank | Check if water supply is normal | / |
| | | | Excessive CO ₂ pressure | Maintain CO ₂ pressure below 0.5MPa | / |
| E7 | Chilling Tank Refill Error | Chilling tank not refilled within 20 minutes | No water supply to chilling tank | Check if water supply is normal | / |
| / | Sparkling Water Dispensing Error | Dispensing fluctuation | CO ₂ pressure too high | Set CO ₂ 0.35-0.4 MPa, dispense 30 s to relieve pressure | / |
| | | | | Faulty CO ₂ gauge may misread. Reduce pressure until smooth | / |
| | | No bubbles in sparkling water | Insufficient CO ₂ in water | CO ₂ ≤ 0.1 MPa. Replace cylinder | / |
| | | | | Follow Initial Sparkling Water Commissioning instructions | / |

Note: Contact after-sales service if above solutions don't resolve the issue

Equipment Assembly Components Overview

1. Dispenser Tap Assembly Components

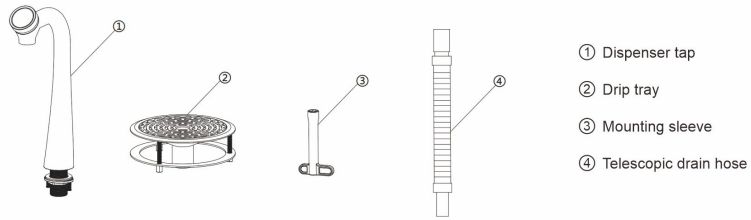

2. Chilling Unit Assembly Components

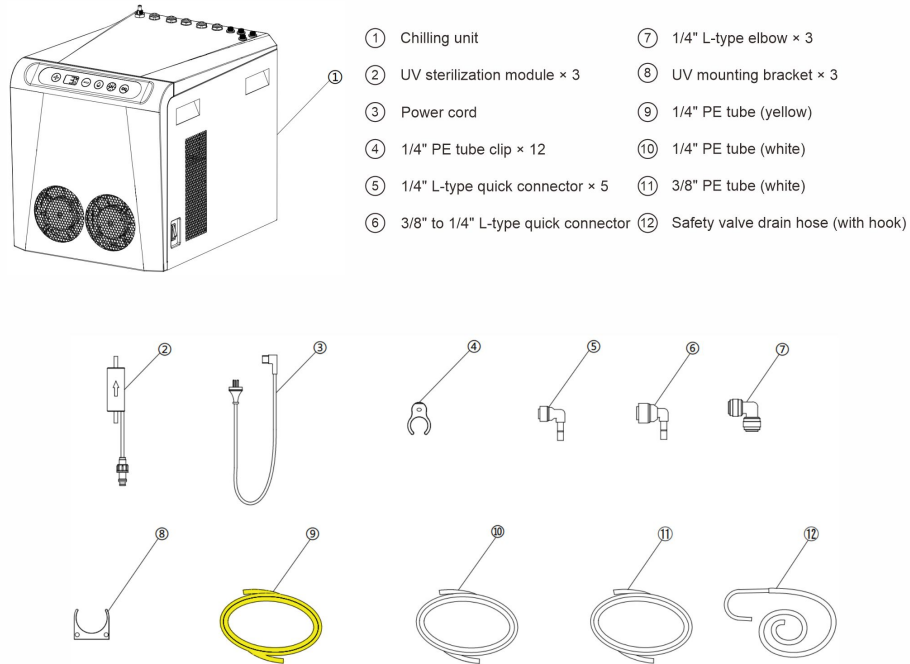

3. RO Filtration Unit Assembly Components

RO filtration unit (optional)

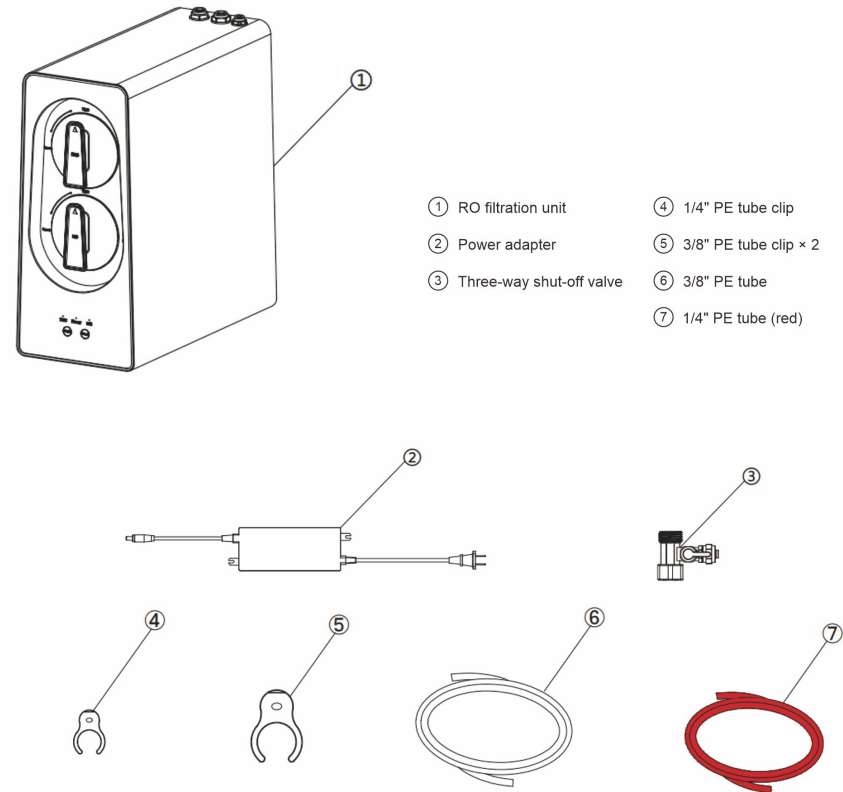

Required Space and Placement Requirements

1. Minimum Clearance for Chilling Unit

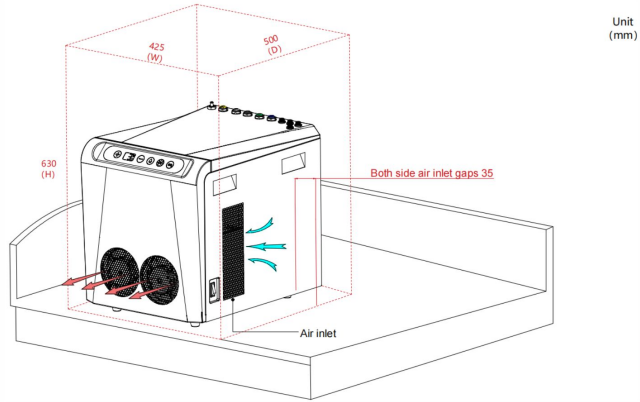

Chilling Unit Size
355 x 464 x 438 (W x D x H)

2. Minimum Clearance for RO Filtration Unit (Applicable only to Bestware Unit)

RO filtration unit (optional)

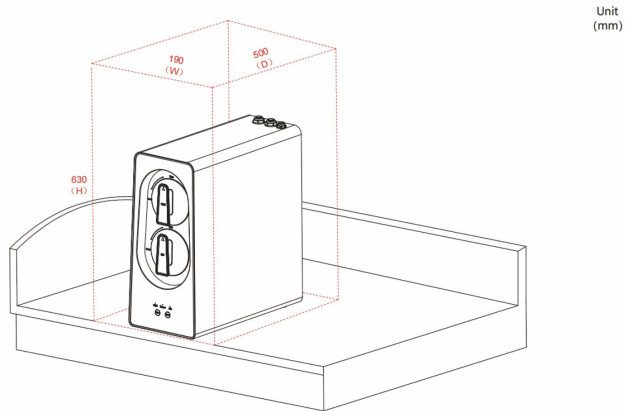

RO Filtration Unit Size
180 x 386 x 408 (W x D x H)

Water and Electrical Positioning Requirements

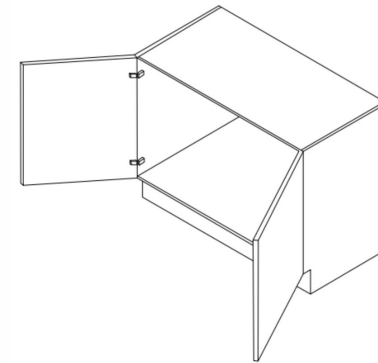

Unit (mm)

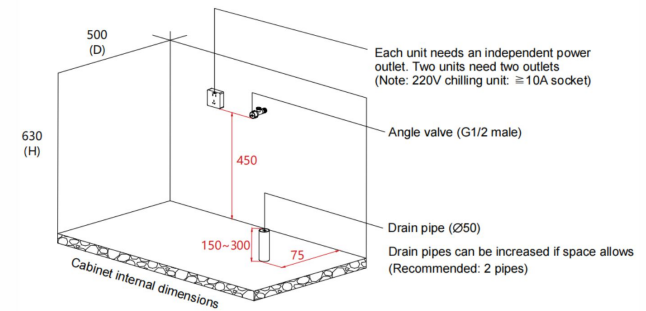

Ventilation Grid Installation

The ventilation grid must be installed to ensure proper ventilation of the unit.

1. Identify the air outlet location of the chilling unit.

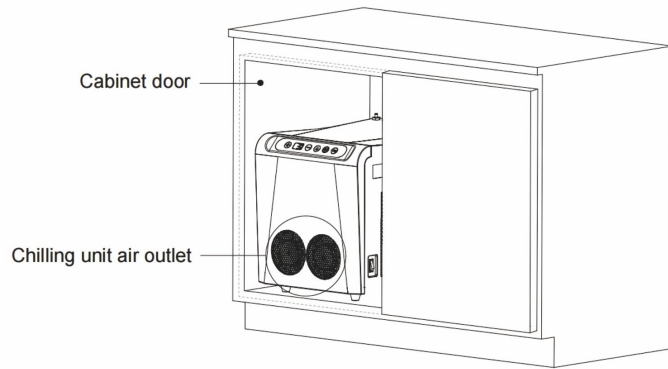

2. Cut an opening on the cabinet door aligned with the air outlet and install the ventilation grid.

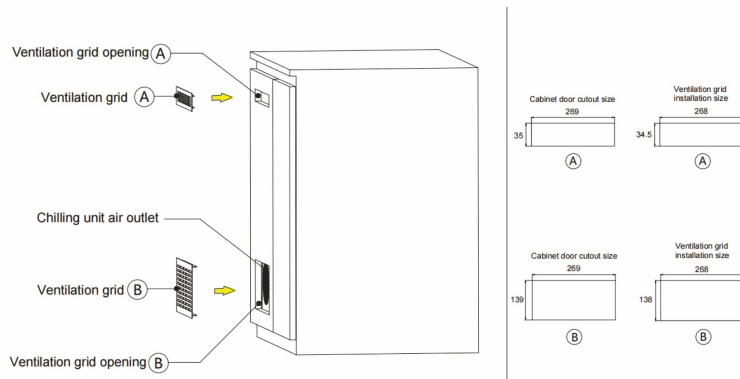

Countertop Cut-out Size

Before installing the dispenser tap, the countertop must be prepared with the required cut-out according to specifications.

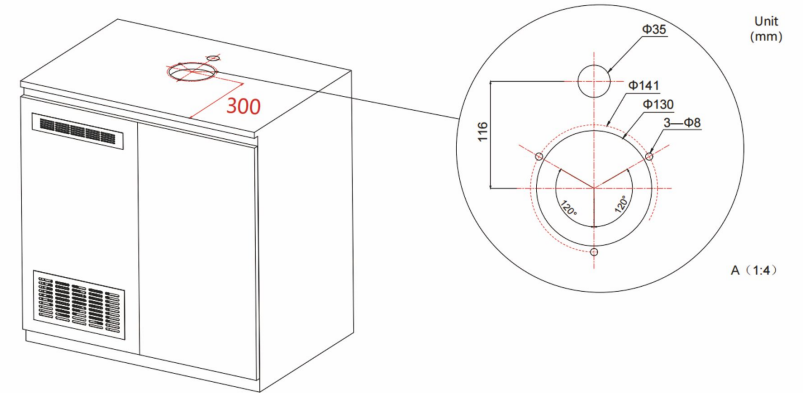

Dispenser Tap Installation Steps

1. Secure Drip Tray: Install the drip tray on the countertop. Secure the nut underneath the countertop first, then tighten it further using the mounting sleeve. (Maximum countertop thickness for drip tray installation: 36mm)

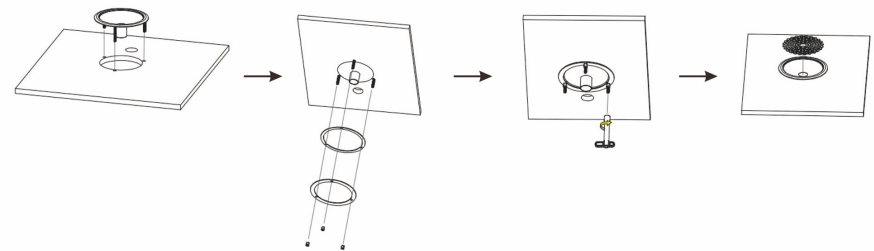

- Secure Dispenser Tap: Install dispenser tap on countertop. First, fasten mounting nut underneath countertop, then tighten using Phillips screwdriver. (Maximum countertop thickness for dispenser tap installation: 40mm)

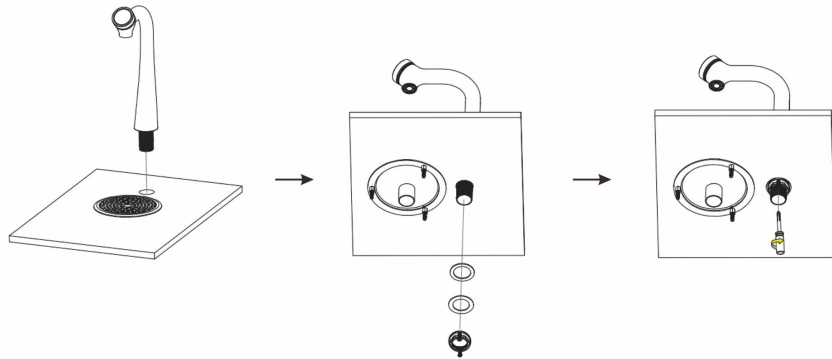

- Install Telescopic Drain Hose: Connect the drip tray and the drain pipe using the telescopic drain hose.

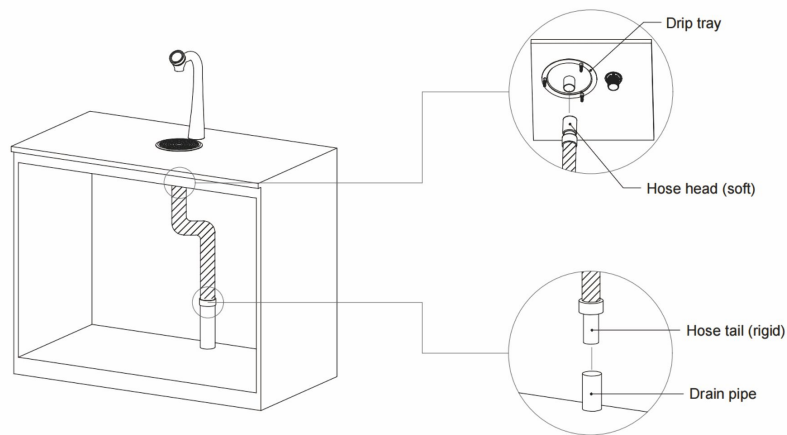

CO₂ Cylinder Precautions



- CO₂ Cylinder Placement: Ensure there is sufficient space to safely secure the cylinder and regulator.

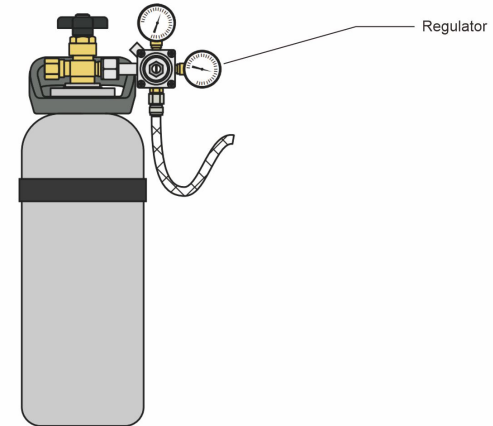

- Secure cylinder vertically to a robust surface with the hook & loop strap and bracket.

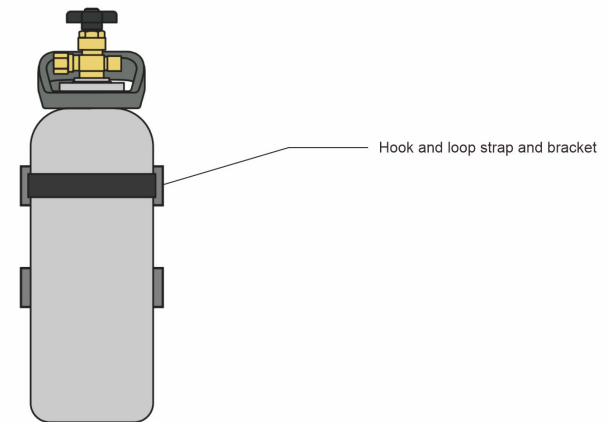

Tubing Connection Precautions

1. Take care to install correctly. No kinks, sags, pinches or loops.
2. The tubes and pipes must not be under tension when installed.
3. PE tubes must be trimmed to avoid loops and kinks. Take care when positioning before cutting and make a clean cut straight across the hose, using a sharp blade.

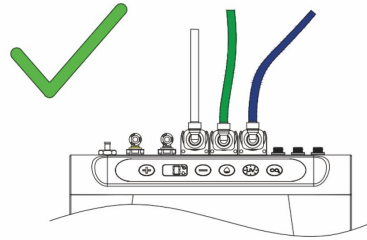
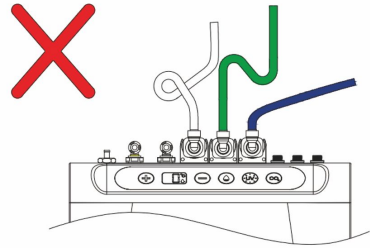

4. Follow the diagram and steps for proper PE tube handling.

Insert

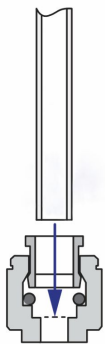

1. Cut tube clean and square.
2. Push tube firmly to end stop.

Remove

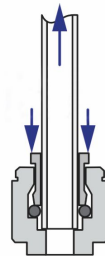

1. Press collet down.
2. Pull tube out.

Communication Cable Connection Precautions

1. When connecting the communication cable, make sure the connectors are properly aligned.

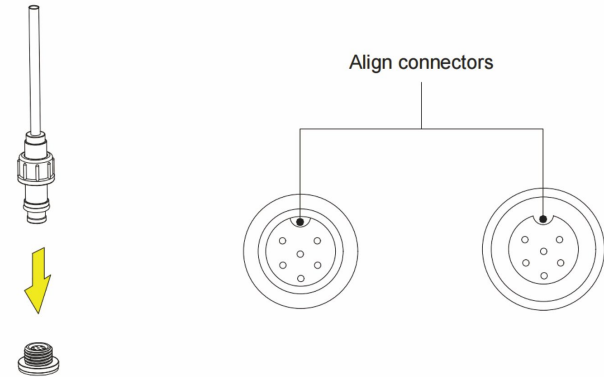

Power-on Precautions

1. Do not connect the power supply before installation is complete to prevent unit malfunction.

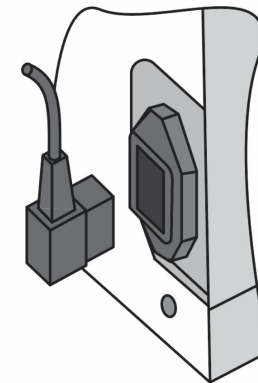

UV Sterilization Module

1. Pay attention to the arrow direction on the UV sterilization module during assembly.

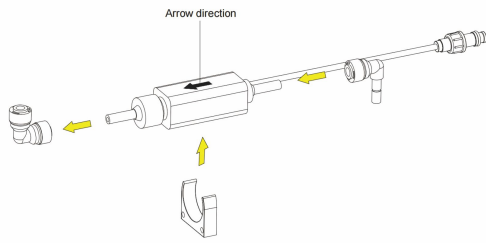

2. After assembling the UV sterilization module, secure it with the tube clip.

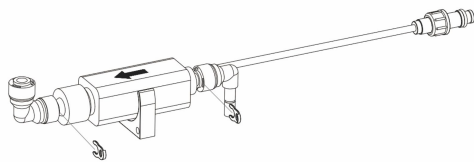

RO Filtration Unit Wastewater Drain Tube Precautions

1. The wastewater drain tube must be securely fixed to the drain pipe to prevent it from popping out due to internal pressure.

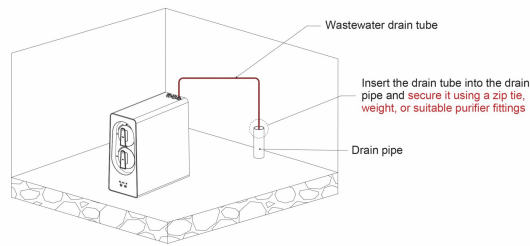

Safety Valve Drain Hose Precautions

1. The safety valve drain hose must be secured to the drain pipe.

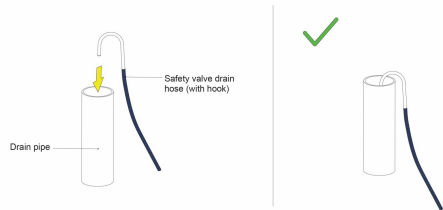

Connection Diagram



Open to left

Connection Diagram

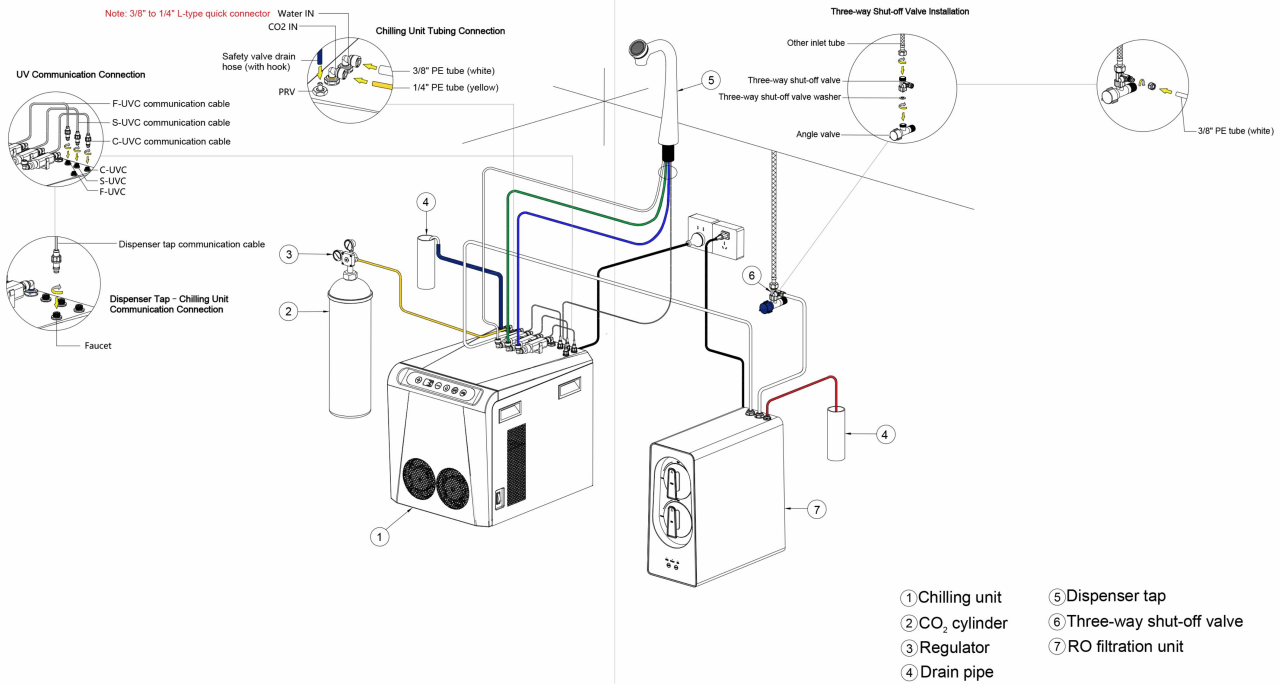

Post-installation Precautions

1. Check that all communication cables, water lines, and PE tubes are correctly connected. After confirming everything is secure, make sure all tube-to-fitting connections are locked in place with tube clips.

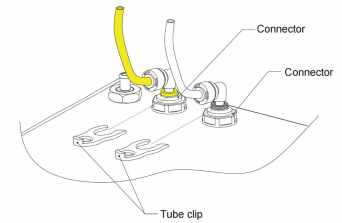

Pre-startup Precautions

1. Water Supply: Open the angle valve first, then open the three-way shut-off valve to supply water.

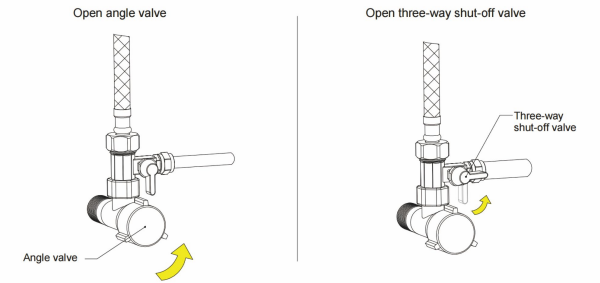

2. Power On Units: After confirming there are no leaks in the piping, turn on the power switches of the chilling unit.

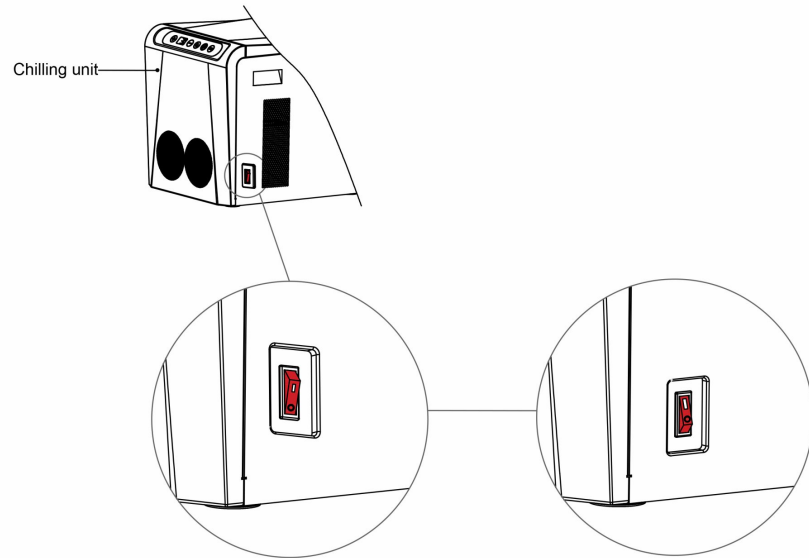

Initial Sparkling Water Commissioning

1. After completing the installation of the commercial sparkling water dispenser, set the chilling unit temperature to 0°C.

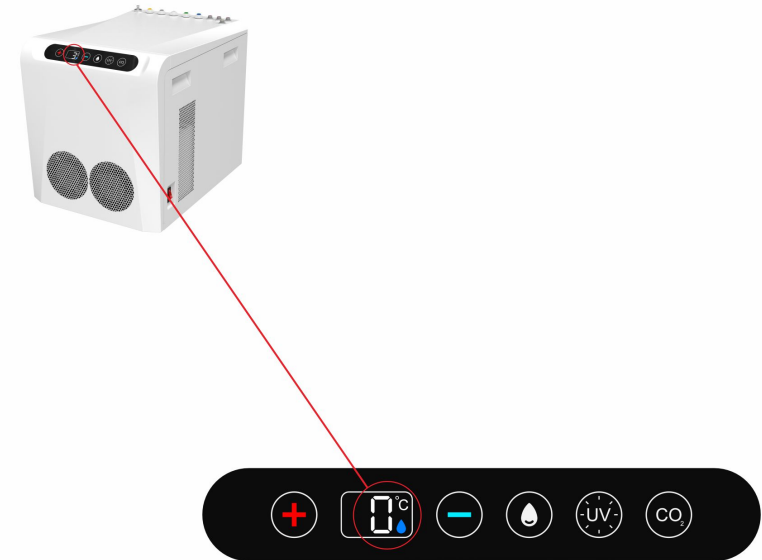

Note: The unit has been commissioned and is ready for use.

Note: Step 2 provides two options. Please select and perform only one.

- 2.1 Shut off the water supply and adjust the CO₂ pressure to 0.35–0.40 MPa (refer to step 5.1); or 2.2 Adjust the CO₂ pressure to 0.55 MPa (refer to step 5.2).

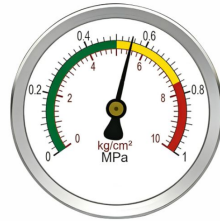
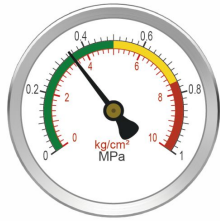

3. Rotate the knob to sparkling water mode and set the dispensing time to 60 seconds.



4. When the real-time temperature of the chilling unit reaches 0 °C, start the initial sparkling water purge by dispensing once in sparkling water mode (60 seconds).



Press the rotary knob to dispense water until only air comes out from the nozzle, then turn off the water dispensing.

- 5.1 (for Step 2.1) Open the water supply. After the chilling unit refills water (3–5 min, depending on inlet flow), let the system sit idle for 1 minute. Turn the screen knob to the sparkling water interface, press to dispense, and check for bubbles and smooth flow. Adjustment complete. Note: Sparkling water dispensing time can be adjusted as needed.



- 5.2 (for Step 2.2) After initial discharge, set the CO₂ pressure to 0.35–0.40 MPa. Once the chilling unit refills water (3–5 min, depending on inlet flow), let the system sit idle for 1 minute. Turn the screen knob to the sparkling water interface, press to dispense, and check for bubbles and smooth flow. Adjustment complete. Note: Sparkling water dispensing time can be adjusted as needed.

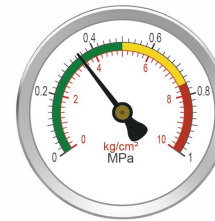

Note: The unit has been commissioned and is ready for use.

Warranty & Disclaimer

● Warranty

Coverage: Full Unit Warranty (applicable only to the original purchaser — B2B customers only; non-transferable)

Scope: Dispenser Tap, Chilling Unit

Period: 18 months from the date of purchase

● Important Notice: This product must be connected to filtered water only (recommended TDS value below 50)

The following conditions are not covered under warranty:

- ① Yellowish water caused by sediment, sand, or impurities in the water source
- ② Malfunctions or irregularities caused by clogged impurities in the water source
- ③ No water output due to limescale buildup
- ④ Reduced cooling performance due to limescale
- ⑤ Malfunctions or irregularities in the chilling unit caused by limescale
- ⑥ Any other operational issues or malfunctions resulting from limescale buildup

● Disclaimer

1. Damage caused by human error or misuse:

- ① Physical damage from collisions, drops, or crushing during transportation or installation
- ② Malfunctions due to unauthorized modifications or the use of non-original parts
- ③ Improper installation or use not in accordance with the instruction manual
- ④ Damage caused by abnormal voltage (e.g., voltage instability) or improper power supply (e.g., no grounding)
- ⑤ Malfunctions due to unsuitable environmental conditions (e.g., excessively high/low temperatures, high humidity, direct sunlight exposure, poor ventilation)
- ⑥ Clogging or damage caused by poor water quality
- ⑦ Malfunctions caused by liquid or foreign objects entering non-designated internal areas of the product
- ⑧ Damage caused by insects, rodents, or pets
- ⑨ Corrosion, discoloration, or deformation caused by improper cleaning (e.g., using strong acids or alkalis)

2. Force Majeure Events:

- ① Natural disasters such as fire, flooding (including water damage from burst pipes), earthquakes, lightning strikes, typhoons, etc.
- ② Accidental events such as damage caused by transportation, war, riots, theft, or government actions
- ③ Interruptions or abnormalities in public utilities, including power, water, and gas supply, resulting in indirect loss or equipment malfunction

3. Damage to Appearance Components or Normal Wear and Tear:

- ① Natural aging of plastic parts or worn labels that do not affect the product's functionality are generally not covered under warranty
- ② Minor scratches, dents, or discoloration occurring during transportation or use that do not affect functionality are typically not covered
- ③ Reasonable performance changes over time—such as slight decreases in cooling efficiency or slight increases in operating noise—are considered normal wear and are not covered by the warranty as long as they remain within acceptable limits

4. Expired Warranty Period:

Warranty services are only provided within the specified valid period

5. Failure to Provide Valid Proof of Purchase:

- ① Inability to present a valid purchase invoice, receipt, or record to confirm the date of purchase
- ② The product serial number label is torn, altered, or illegible (this is generally considered grounds for disqualification from warranty coverage)

6. Unauthorized Repairs:

During the warranty period, any repair conducted by an unauthorized party or performed without official approval from the brand may void the warranty

● Warranty Service Procedure

1. How to Request Service:

- ① Customer Service Hotline: +86 750 3108801 (Weekdays, 8:30-17:30)
- ② after-sales@bestware-stainless.com
- ③ Contact your sales representative

2. Required Documentation:

Please provide a valid original purchase invoice, electronic order, purchase record, or purchase contract

● Special Notes

- ① Out-of-Warranty Repairs: A fee will be charged, including the cost of parts and a service fee (Standard rate: ____ CNY/visit)
- ② Extended Warranty: Additional warranty coverage of ____ years is available for purchase (please consult your sales representative for details)
- ③ Policy Updates: Brand policies are subject to change. Please refer to the latest official announcements on our website

⚠ Important Recommendations:

- ① Please review the warranty disclaimers carefully before purchase, and read the user manual thoroughly to ensure proper product usage
- ② Keep your proof of purchase safely during the warranty period

● Right of Interpretation:

The company reserves the final right of interpretation for the warranty terms and disclaimer scope

